

SCHEMATIC

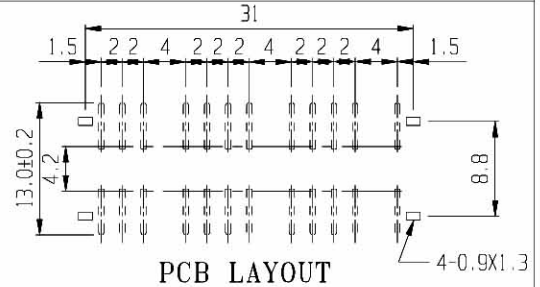

PCB LAYOUT

2- ϕ 2.2 or
2-M2.6X0.45

**RoHS
Compliance**

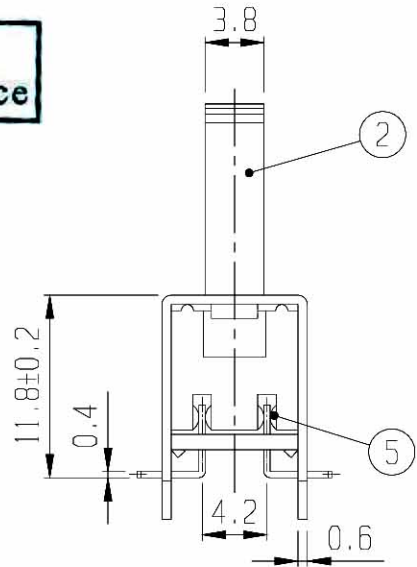
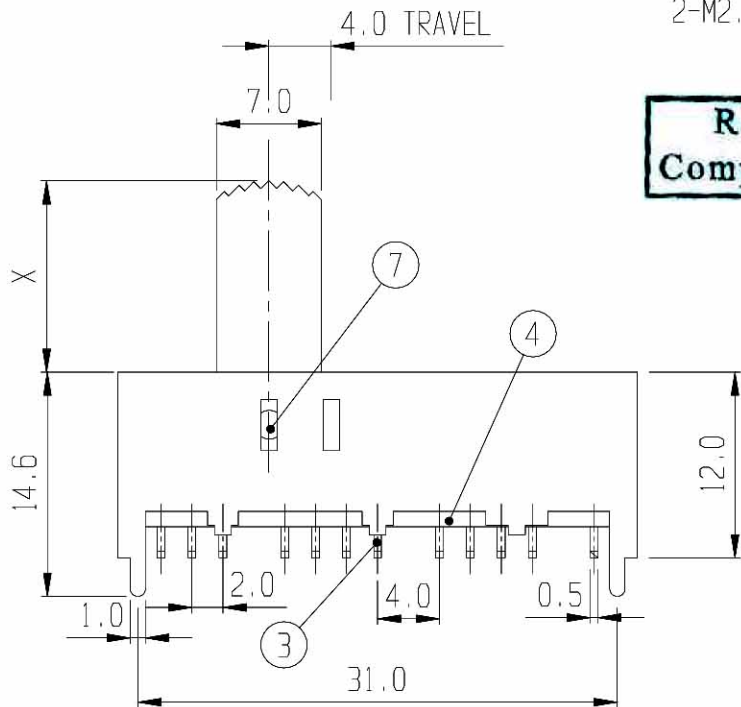

NO	PART	MATERIAL	QTY	REMARKS	NO	PART	MATERIAL	QTY	REMARKS
7	BALL	STEEL	2		6	SPRING	STEEL WIRE	1	
5	CONTACT	P B S	6	Ag PLATED	4	TERMINAL BASE	PHENOL RESIN	1	NATURAL
3	TERMINAL	BRASS	24	Ag PLATED	2	KNOB	P O M	1	G 2-15
1	FRAME	S P C C	1	Ni PLATED					

ISSUED	SPECIFICATION	TITLE: SLIDE SWITCH (6P2T)		
	RATING: DC 30V 0.3A	MODEL NO: SS-62H03		
	CONTACT RESISTANCE: 30m Ω max.	TOLERANCE	UNIT: MM	DWN. <i>hno</i>
	INSULATION RESISTANCE: 500M Ω at 500V DC	UP TO 1.0:±0.1	SCALE: 2:1	CHK'D. <i>pu</i>
	WITHSTAND VOLTAGE: AC 500V for 1 minute	1.0 TO 10.0:±0.2	VERSION: 01	APPD. <i>[Signature]</i>
	OPERATION FORCE: REFER ATTACH SPECIFICATION	OVER 10.0:±0.3	DRWG NO:	
	SWITCHING LIFE: 10K cycles min.			

BY: *[Signature]*
DATE: 05-JUN-1999

