

SCHEMATIC

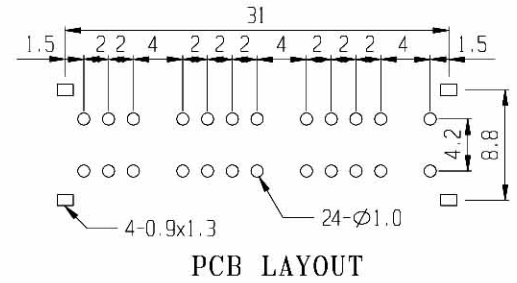

PCB LAYOUT

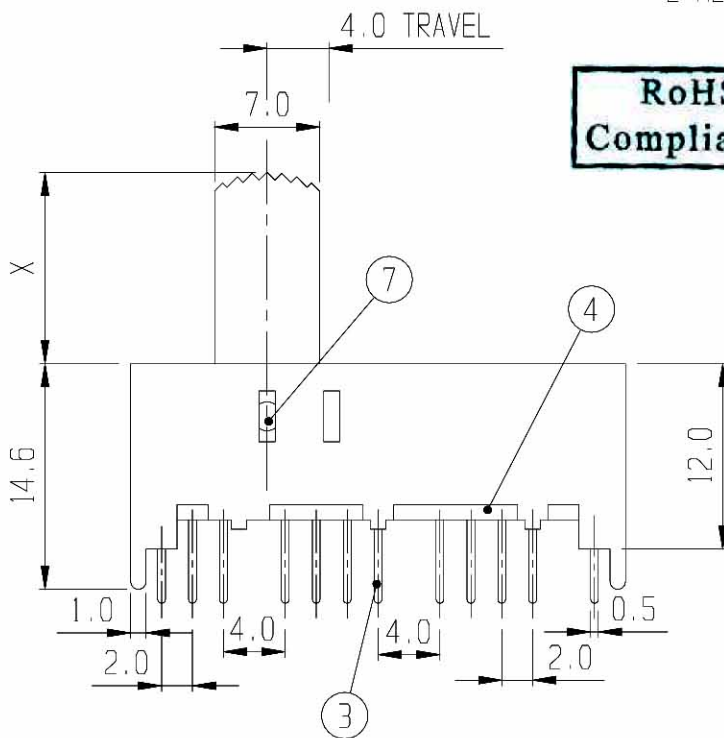

**RoHS Compliance**

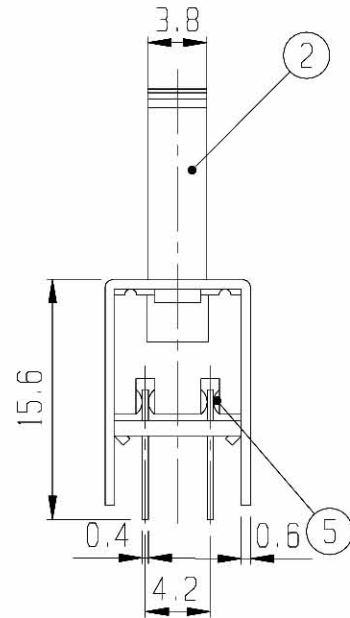

7	BALL	STEEL	2						
5	CONTACT	P B S	6	Ag PLATED	6	SPRING	STEEL WIRE	1	
3	TERMINAL	BRASS	24	Ag PLATED	4	TERMINAL BASE	PHENOL RESIN	1 NATURAL	
1	FRAME	S P C C	1	Ni PLATED	2	KNOB	P O M	1 G 2-15	
NO	PART	MATERIAL	QTY	REMARKS	NO	PART	MATERIAL	QTY	REMARKS

ISSUED	SPECIFICATION				TITLE: SLIDE SWITCH (6P2T)				
	RATING: DC 30V 0.3A				MODEL NO: SS-62H01				
	CONTACT RESISTANCE: 30mΩ max.				TOLERANCE		UNIT: MM		DWN.
	INSULATION RESISTANCE: 500MΩ at 500V DC				UP TO 1.0:±0.1		SCALE: 2:1		
	WITHSTAND VOLTAGE: AC 500V for 1 minute				1.0 TO 10.0:±0.2		VERSION: 01		CHK'D.
	OPERATION FORCE: REFER ATTACH SPECIFICATION				OVER 10.0:±0.3		DRWG NO:		APPD.
	SWITCHING LIFE: 10K cycles min.								

BY:   
DATE: 08-MAR-2000

