

SCHMATIC

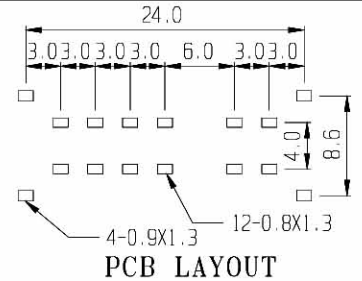

PCB LAYOUT

RoHS Compliance

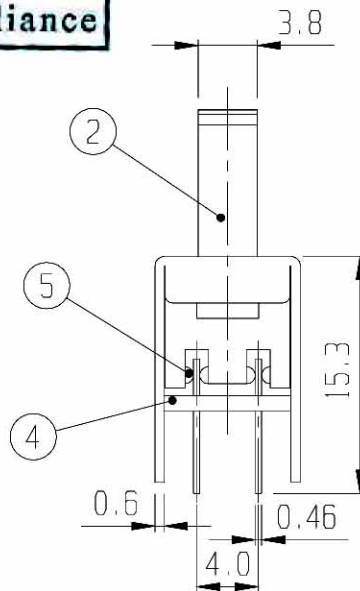
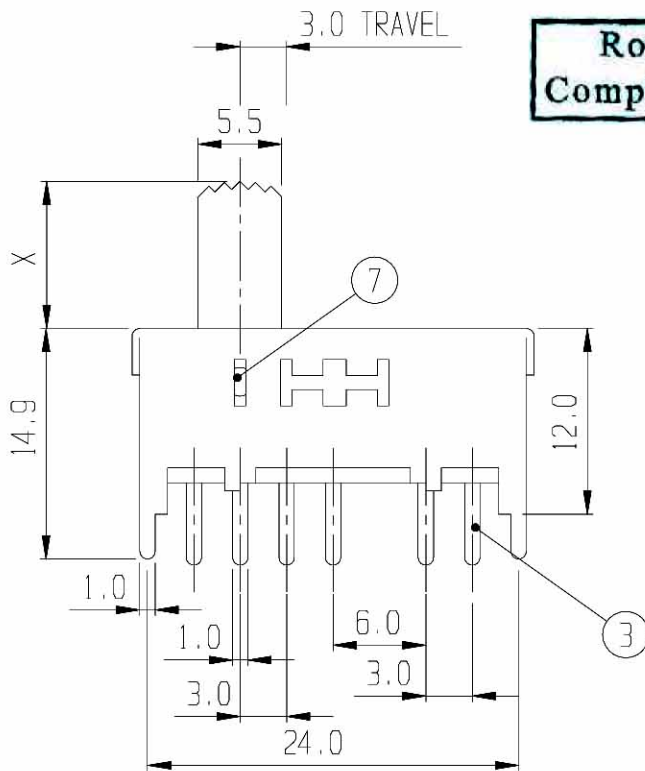

7	BALL	STEEL	2						
5	CONTACT	P B S	2	Ag PLATED	6	SPRING	STEEL WIRE	1	
3	TERMINAL	BRASS	12	Ag PLATED	4	TERMINAL BASE	PHENOL RESIN	1 NATURAL	
1	FRAME	S P C C	1	Ni PLATED	2	KNOB	P O M	1 G 2-18	
NO	PART	MATERIAL	QTY	REMARKS	NO	PART	MATERIAL	QTY	REMARKS

ISSUED

SPECIFICATION

TITLE: SLIDE SWITCH (2P5T)

RATING: DC 30V 0.5A

CONTACT RESISTANCE: 30mΩ max.

INSULATION RESISTANCE: 500MΩ at 500V DC

WITHSTAND VOLTAGE: AC 500V for 1 minute

OPERATION FORCE: REFER ATTACH SPECIFICATION

SWITCHING LIFE: 10K cycles min.

MODEL NO: SS-25F02

TOLERANCE

UNIT: MM

DWN.

UP TO 1.0:±0.1

SCALE: 2:1

CHK'D.

1.0 TO 10.0:±0.2

VERSION: 01

APPD.

OVER 10.0:±0.3

DRWG NO:

BY:

DATE: 10-JUN-1999

VIMEX
INTERNATIONAL CORPORATION

