

RoHS Compliance

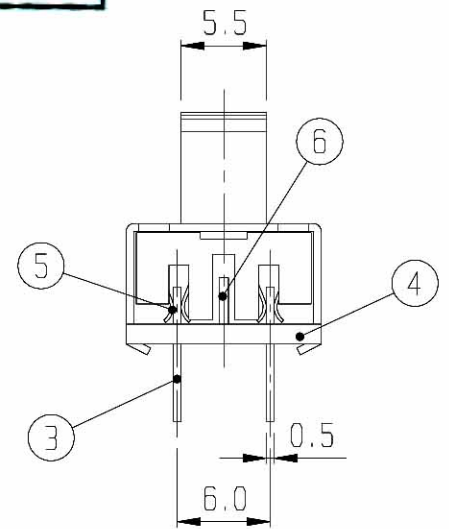
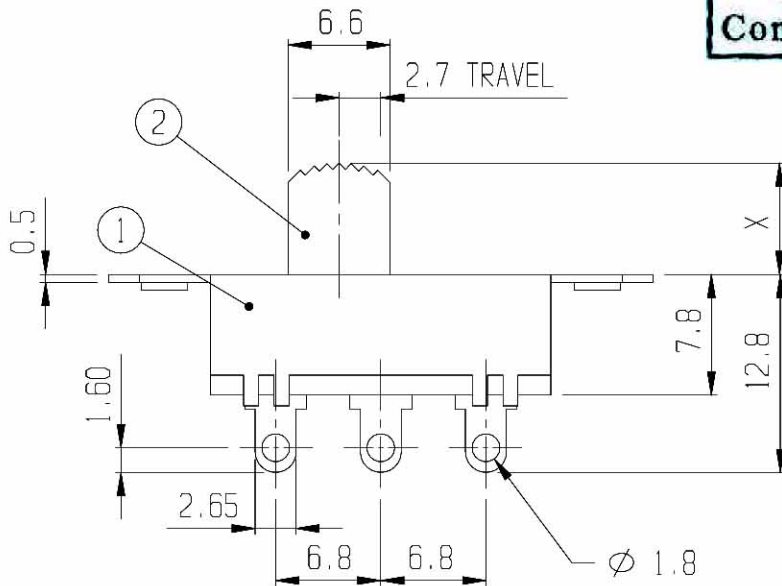

7	SPRING	STEEL WIRE	1		8	BALL	STEEL	1	
5	CONTACT	P B S	2	Ag PLATED	6	CENTER PLATE	S P C C	1	Ni PLATED
3	TERMINAL	BRASS	6	Ag PLATED	4	TERMINAL BASE	PHENOL RESIN	1	NATURAL
1	FRAME	S P C C	1	BLACK PLATED	2	KNOB	P C	1	G 3.2-10
NO	PART	MATERIAL	QTY	REMARKS	NO	PART	MATERIAL	QTY	REMARKS

ISSUED

SPECIFICATION

TITLE: SLIDE SWITCH (2P3T)

RATING: AC 250V 0.3A; AC 125V 1A; DC 50V 0.5A
CONTACT RESISTANCE: 30mΩ max.

MODEL NO: SS-23F19

INSULATION RESISTANCE: 500MΩ at 500V DC

TOLERANCE UNIT: MM

DWN. *hno*

WITHSTAND VOLTAGE: AC 500V for 1 minute

UP TO 1.0:±0.1 SCALE: 2:1

CHK'D. *pu*

OPERATION FORCE: REFER ATTACH SPECIFICATION

1.0 TO 10.0:±0.2 VERSION: 02

SWITCHING LIFE: 10K cycles min.

OVER 10.0:±0.3 DRWG NO:

APPD. *[Signature]*

BY: *[Signature]*

DATE: 11-MAY-2006

VIMEX
INTERNATIONAL CORPORATION

