

**SCHEMATIC**

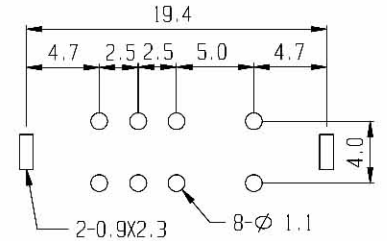

**PCB LAYOUT**

**RoHS Compliance**

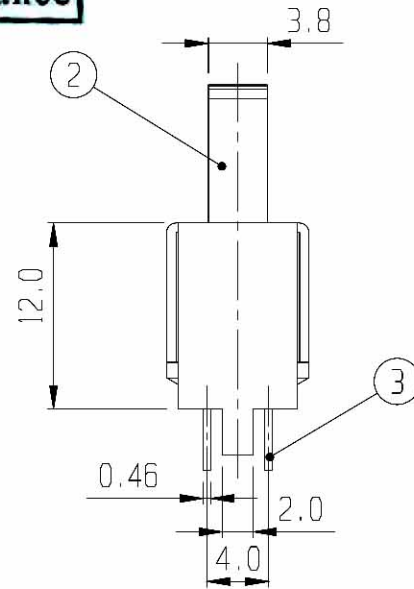
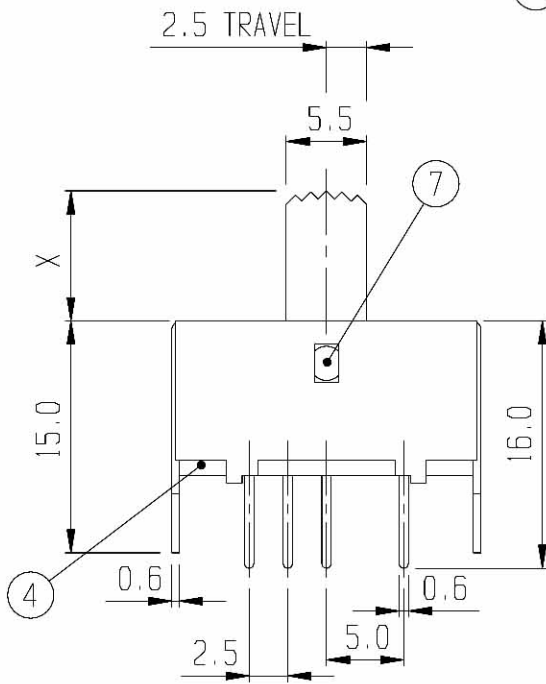

7	BALL	STEEL	2						
5	CONTACT	P B S	2	Ag PLATED	6	SPRING	STEEL WIRE	1	
3	TERMINAL	BRASS	8	Ag PLATED	4	TERMINAL BASE	PHENOL RESIN	1 NATURAL	
1	FRAME	S P C C	1	Ni PLATED	2	KNOB	P O M	1 G 2-18	
NO	PART	MATERIAL	QTY	REMARKS	NO	PART	MATERIAL	QTY	REMARKS

<b>ISSUED</b>	<b>SPECIFICATION</b>	<b>TITLE: SLIDE SWITCH (2P3T)</b>		
	RATING: DC 30V 0.5A	MODEL NO: SS-23E01		
	CONTACT RESISTANCE: 30mΩ max.			
	INSULATION RESISTANCE: 500MΩ at 500V DC	TOLERANCE	UNIT: MM	DWN. <i>hro</i>
	WITHSTAND VOLTAGE: AC 500V for 1 minute	UP TO 1.0:±0.1	SCALE: 2:1	CHK'D. <i>hro</i>
	OPERATION FORCE: REFER ATTACH SPECIFICATION	1.0 TO 10.0:±0.2	VERSION: 01	APPD. <i>hro</i>
	SWITCHING LIFE: 10K cycles min.	OVER 10.0:±0.3	DRWG NO:	

BY: *[Signature]*  
DATE: 10-JUN-1999

