

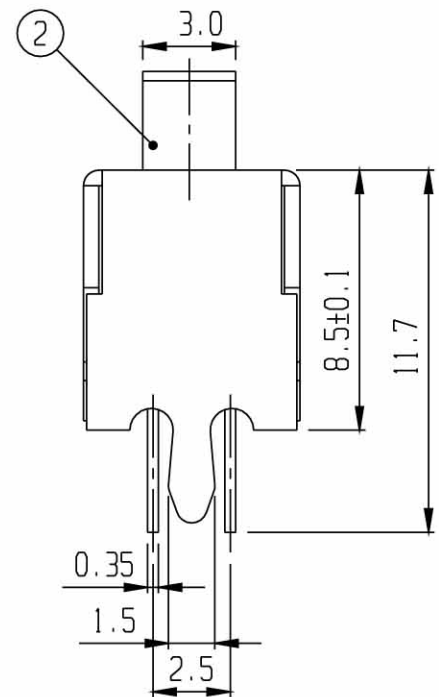

NON-SHORTING

RoHS  
Compliance

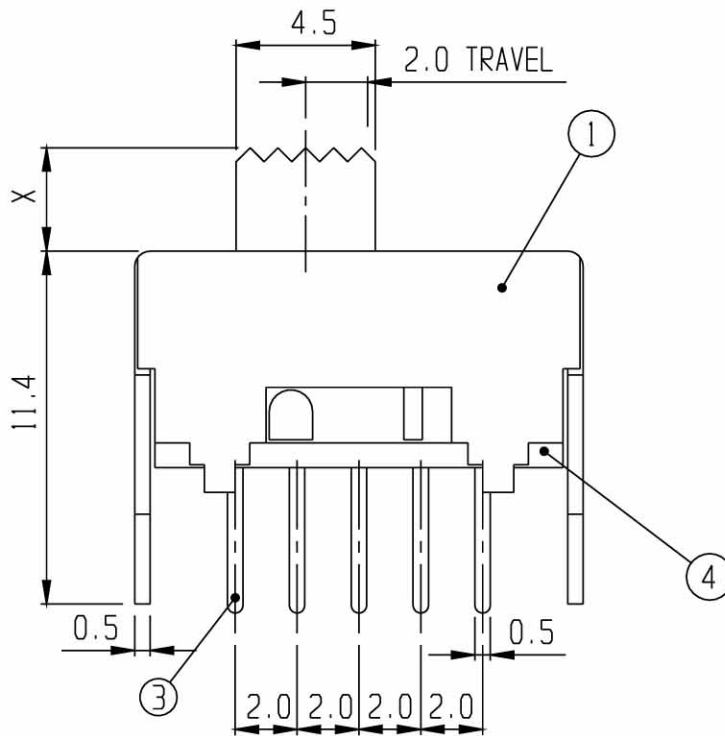
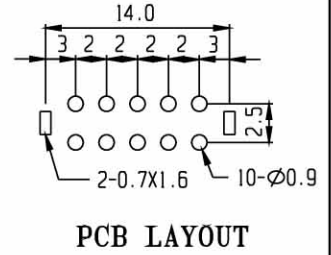
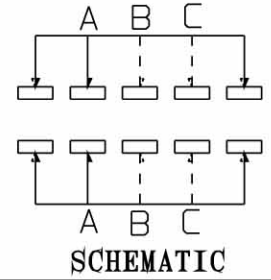

5	CONTACT	P B S	2	Ag PLATED	6	SPRING PLATE	S U S	1	
3	TERMINAL	BRASS	10	Ag PLATED	4	TERMINAL BASE	PHENOL RESIN	1	NATURAL
1	FRAME	S P C C	1	Ni PLATED	2	KNOB	P O M	1	EG 2.5-10
NO	PART	MATERIAL	QTY	REMARKS	NO	PART	MATERIAL	QTY	REMARKS

ISSUED	SPECIFICATION	TITLE: SLIDE SWITCH (2P3T)		
	RATING: DC 30V 0.3A	MODEL NO: SS-23D06		
	CONTACT RESISTANCE: 30mΩ max.			
	INSULATION RESISTANCE: 500MΩ at 500V DC	TOLERANCE	UNIT: MM	DWN.
	WITHSTAND VOLTAGE: AC 500V for 1 minute	UP TO 1.0:±0.1	SCALE: 4:1	CHK'D.
	OPERATION FORCE: REFER ATTACH SPECIFICATION	1.0 TO 10.0:±0.2	VERSION: 02	APPD.
	SWITCHING LIFE: 10K cycles min.	OVER 10.0:±0.3	DRWG NO:	

BY:   
DATE: 07-SEP-2007

