

Non-shorting

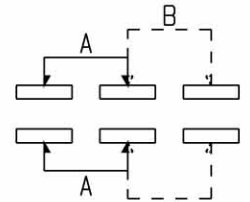

SCHEMATIC

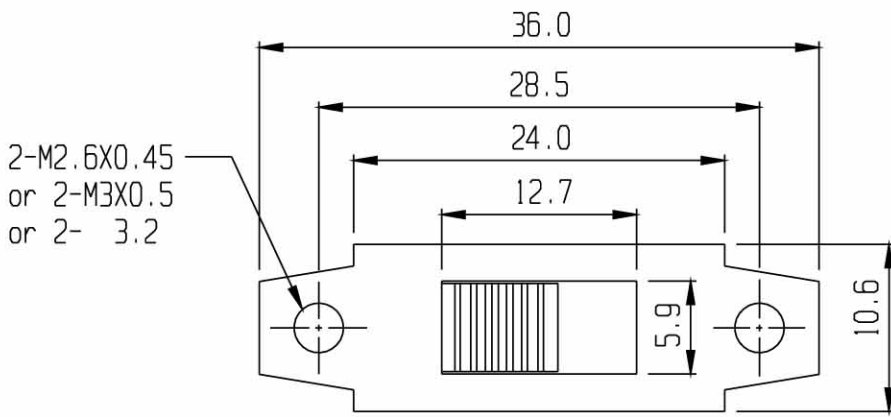
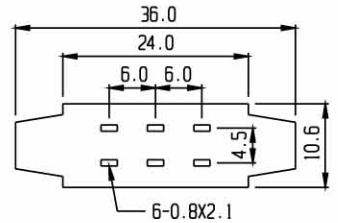

PCB LAYOUT

RoHS Compliance

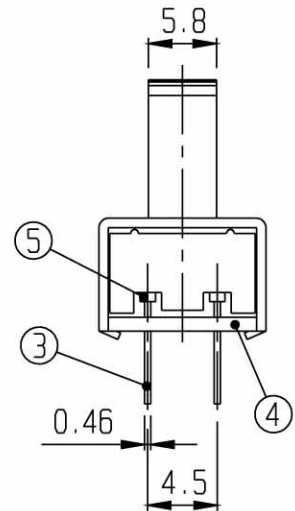
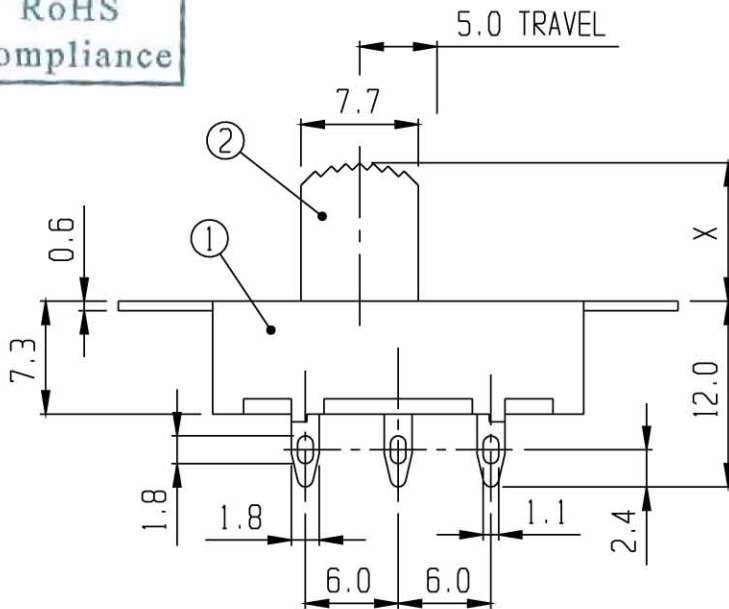

5	CONTACT	BRASS	2	Ag PLATED	6	SPRING	STEEL WIRE	2	
3	TERMINAL	BRASS	6	Ag PLATED	4	TERMINAL BASE	PHENOL RESIN	1	NATURAL
1	FRAME	SPCC	1	BLACK PLATED	2	KNOB	A B S	1	G 2-12
NO	PART	MATERIAL	QTY	REMARKS	NO	PART	MATERIAL	QTY	REMARKS

ISSUED	SPECIFICATION	TITLE: SLIDE SWITCH (2P2T)		
	RATING: 1A 250V AC / 2A 125V AC	MODEL NO: SS-22J01		
	CONTACT RESISTANCE: 30mΩ max.	TOLERANCE	UNIT: MM	DWN. <i>hro</i>
	INSULATION RESISTANCE: 500MΩ at 500V DC	UP TO 1.0: α0.1	SCALE: 2:1	CHK'D. <i>mu</i>
	WITHSTAND VOLTAGE: AC 500V for 1 minute	1.0 TO 10.0: α0.2	VERSION: 02	APPD. <i>[Signature]</i>
	OPERATION FORCE: REFER ATTACH SPECIFICATION	OVER 10.0: α0.3	DRWG NO:	
	SWITCHING LIFE: 10K cycles min.			

BY: *[Signature]*  
DATE: 28-OCT-2005

