

SCHEMATIC

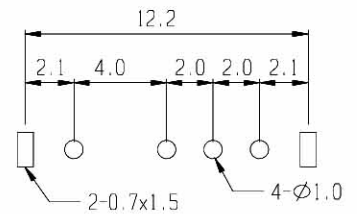

PCB LAYOUT

**RoHS  
Compliance**

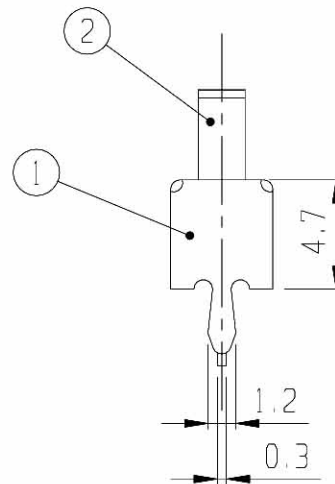
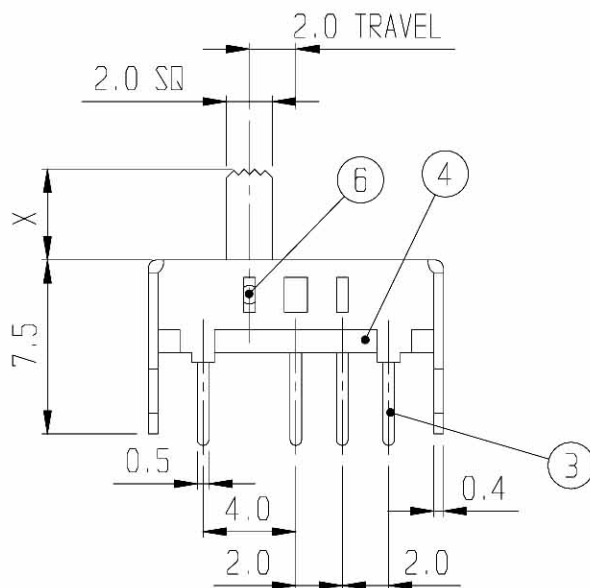

5	CONTACT	P B S	1	Ag PLATED	6	SPRING	P B S	2	
3	TERMINAL	BRASS	4	Ag PLATED	4	TERMINAL BASE	PHENOL RESIN	1	NATURAL
1	FRAME	S P C C	1	Ni PLATED	2	KNOB	P O M	1	G 2-10
NO	PART	MATERIAL	QTY	REMARKS	NO	PART	MATERIAL	QTY	REMARKS

ISSUED

SPECIFICATION

TITLE: SLIDE SWITCH (1P3T)

RATING: DC 30V 0.5A  
 CONTACT RESISTANCE: 30mΩ max.  
 INSULATION RESISTANCE: 500MΩ at 500V DC  
 WITHSTAND VOLTAGE: AC 500V for 1 minute  
 OPERATION FORCE: REFER ATTACH SPECIFICATION  
 SWITCHING LIFE: 10K cycles min.

MODEL NO: SS-13D03

TOLERANCE UNIT: MM  
 UP TO 1.0:±0.1 SCALE: 3:1  
 1.0 TO 10.0:±0.2 VERSION: 01  
 OVER 10.0:±0.3 DRWG NO:

DWN. *hro*  
 CHK'D. *hro*  
 APPD. *hro*

BY: *hro*

DATE: 09-MAR-2005

