

Non-shorting

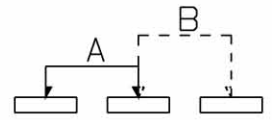

SCHEMATIC

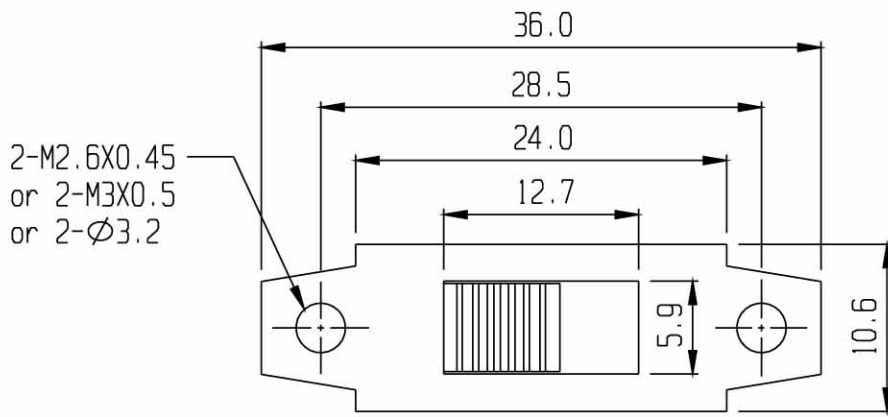
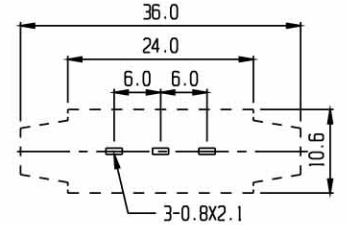

PCB LAYOUT

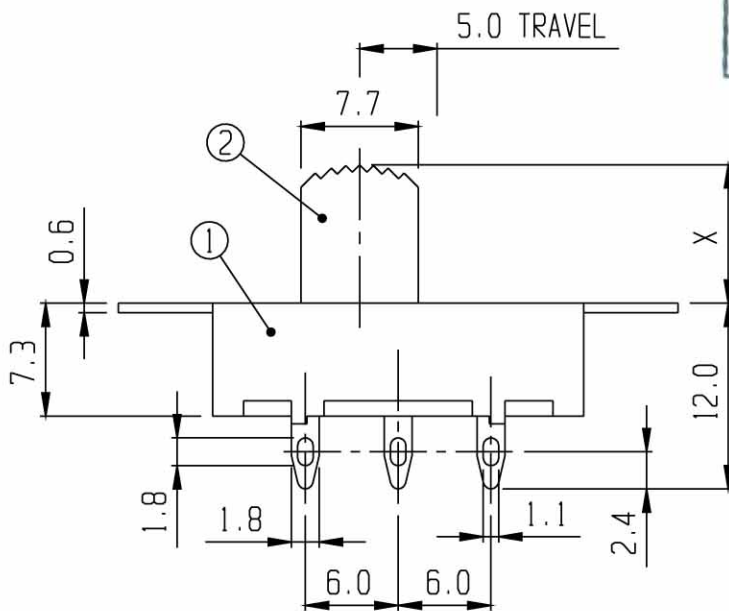

RoHS Compliance

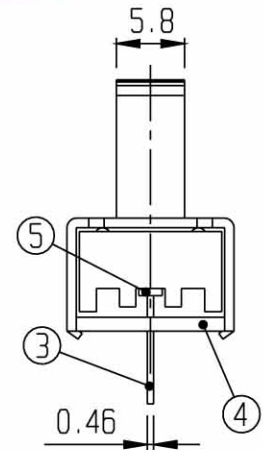

5	CONTACT	BRASS	1	Ag PLATED	6	SPRING	STEEL WIRE	1	
3	TERMINAL	BRASS	3	Ag PLATED	4	TERMINAL BASE	PHENOL RESIN	1	NATURAL
1	FRAME	SPCC	1	BLACK PLATED	2	KNOB	A B S	1	G 2-12
NO	PART	MATERIAL	QTY	REMARKS	NO	PART	MATERIAL	QTY	REMARKS

ISSUED

SPECIFICATION

TITLE: SLIDE SWITCH (1P2T)

RATING: 1A 250V AC / 2A 125V AC

CONTACT RESISTANCE: 30mΩ max.

INSULATION RESISTANCE: 500MΩ at 500V DC

WITHSTAND VOLTAGE: AC 500V for 1 minute

OPERATION FORCE: REFER ATTACH SPECIFICATION

SWITCHING LIFE: 10K cycles min.

MODEL NO: SS-12J11

TOLERANCE UNIT: MM

UP TO 1.0:±0.1 SCALE: 2:1

1.0 TO 10.0:±0.2 VERSION: 02

OVER 10.0:±0.3 DRWG NO:

DWN. *hro*

CHK'D. *pm*

APPD. *[Signature]*

BY: *[Signature]*

DATE: 28-OCT-2005

