

**SCHEMATIC**

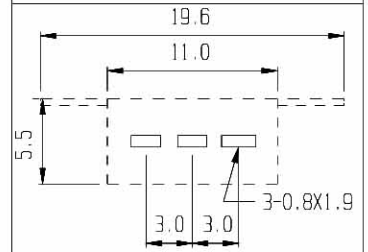

**PCB LAYOUT**

**RoHS  
Compliance**

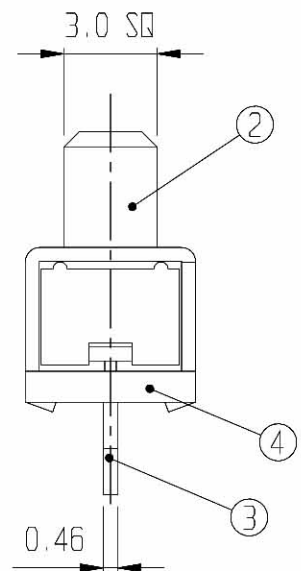
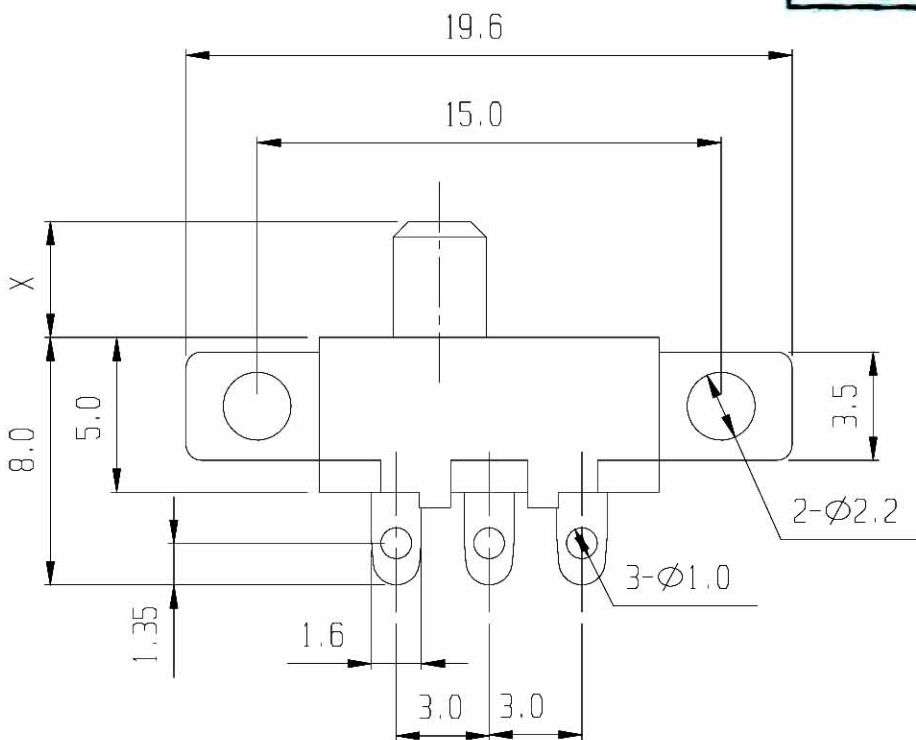

5	CONTACT	BRASS	1	Ag PLATED	6	SPRING	STEEL WIRE	1	
3	TERMINAL	BRASS	3	Ag PLATED	4	TERMINAL BASE	PHENOL RESIN	1	NATURAL
1	FRAME	SPCC	1	BLACK PLATED	2	KNOB	P O M	1	CG 2-15
NO	PART	MATERIAL	QTY	REMARKS	NO	PART	MATERIAL	QTY	REMARKS

<b>ISSUED</b>	<b>SPECIFICATION</b>	<b>TITLE: SLIDE SWITCH (1P2T)</b>							
	RATING: DC 30V 0.3A	<b>MODEL NO: SS-12F75</b>							
	CONTACT RESISTANCE: 30mΩ max.								
	INSULATION RESISTANCE: 500MΩ at 500V DC	TOLERANCE	UNIT: MM	DWN.	<i>hro</i>				
	WITHSTAND VOLTAGE: AC 500V for 1 minute	UP TO 1.0:±0.1	SCALE: 4:1	CHK'D.	<i>hro</i>				
	OPERATION FORCE: REFER ATTACH SPECIFICATION	1.0 TO 10.0:±0.2	VERSION: 02	APPD.	<i>[Signature]</i>				
	SWITCHING LIFE: 10K cycles min.	OVER 10.0:±0.3	DRWG NO:						

BY: *[Signature]*  
DATE: 30-NOV-2004

