

RoHS Compliance

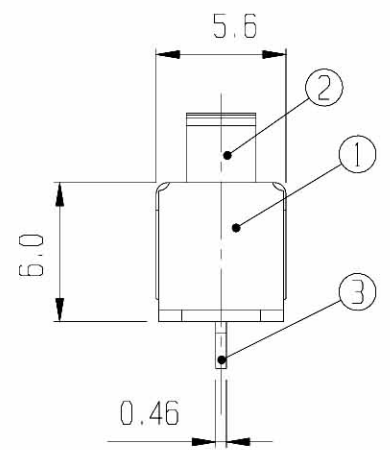
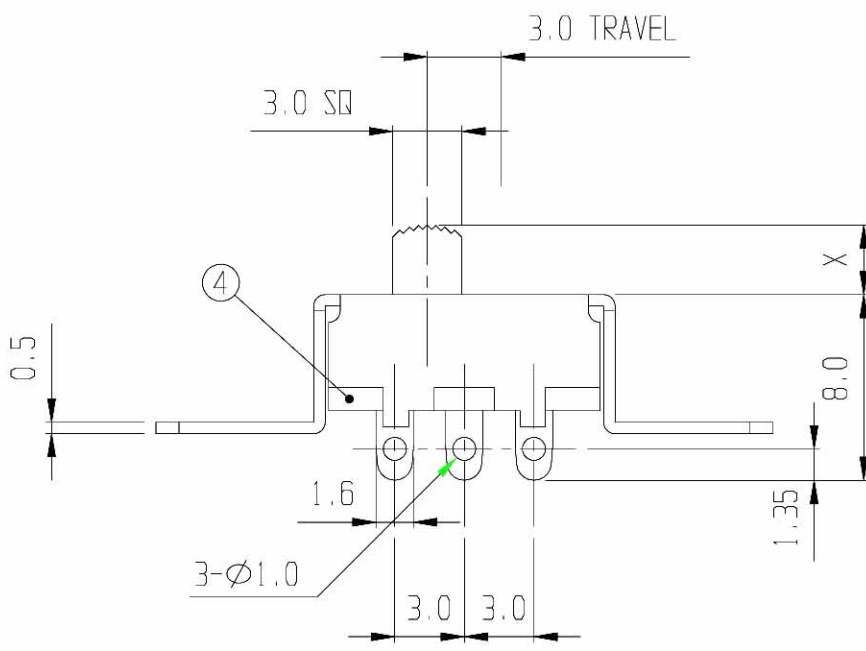

5	CONTACT	BRASS	1	Ag PLATED	6	SPRING	STEEL WIRE	1	
3	TERMINAL	BRASS	3	Ag PLATED	4	TERMINAL BASE	PHENOL RESIN	1	NATURAL
1	FRAME	SPCC	1	Ni PLATED	2	KNOB	P O M	1	G 2-15
NO	PART	MATERIAL	QTY	REMARKS	NO	PART	MATERIAL	QTY	REMARKS

ISSUED	SPECIFICATION	TITLE: SLIDE SWITCH (1P2T)		
	RATING: DC 30V 0.3A	MODEL NO: SS-12F48		
	CONTACT RESISTANCE: 30mΩ max.			
	INSULATION RESISTANCE: 500MΩ at 500V DC	TOLERANCE	UNIT: MM	DWN.
	WITHSTAND VOLTAGE: AC 500V for 1 minute	UP TO 1.0:±0.1	SCALE: 3:1	CHK'D.
	OPERATION FORCE: REFER ATTACH SPECIFICATION	1.0 TO 10.0:±0.2	VERSION: 01	APPD.
	SWITCHING LIFE: 10K cycles min.	OVER 10.0:±0.3	DRWG NO:	

BY:
DATE: 08-DEC-2000

