

**RoHS
Compliance**

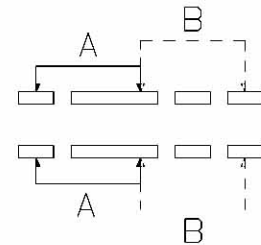

SCHEMATIC

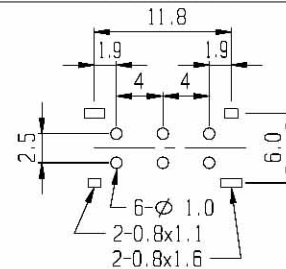

PCB LAYOUT

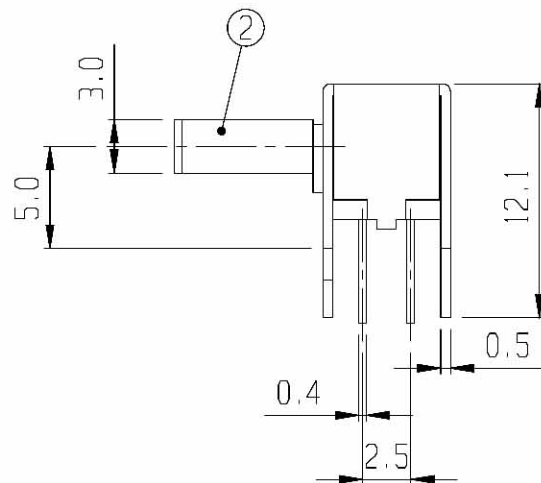
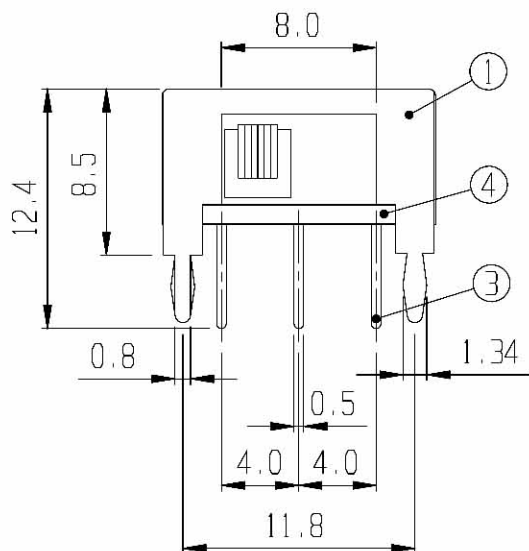

7	BALL	STEEL	1						
5	CONTACT	P B S	2	Ag PLATED	6	SPRING	STEEL WIRE	1	
3	TERMINAL	BRASS	6	Ag PLATED	4	TERMINAL BASE	PHENOL RESIN	1 NATURAL	
1	FRAME	S P C C	1	Ni PLATED	2	KNOB	P O M	1 GBH 2-15	
NO	PART	MATERIAL	QTY	REMARKS	NO	PART	MATERIAL	QTY	REMARKS

ISSUED

SPECIFICATION

TITLE: SIDE KNOB SLIDE SWITCH (2P2T)

RATING: DC 30V 0.3A

CONTACT RESISTANCE: 30mΩ max.

INSULATION RESISTANCE: 500MΩ at 500V DC

WITHSTAND VOLTAGE: AC 500V for 1 minute

OPERATION FORCE: REFER ATTACH SPECIFICATION

SWITCHING LIFE: 10K cycles min.

MODEL NO: SK-22H04

TOLERANCE

UNIT: MM

UP TO 1.0:±0.1

SCALE: 2:1

1.0 TO 10.0:±0.2

VERSION: 01

OVER 10.0:±0.3

DRWG NO:

DWN.

CHK'D.

APPD.

BY:

DATE: 10-MAR-2000

VIMEX
INTERNATIONAL CORPORATION

