

SCHEMATIC

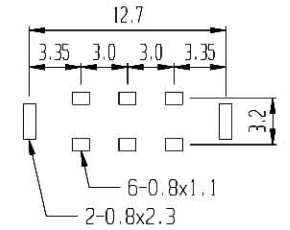

PCB LAYOUT

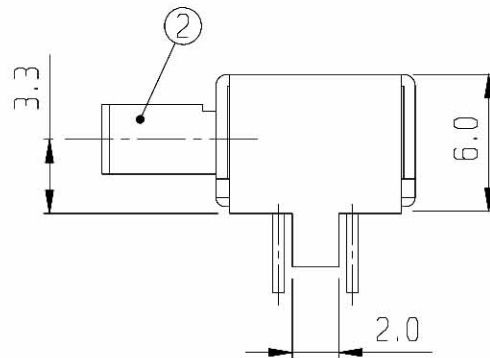
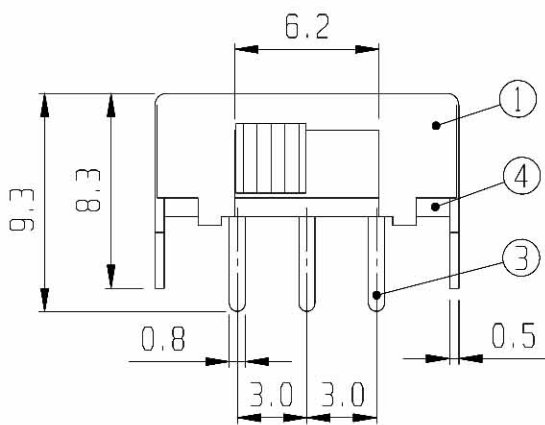

**RoHS
Compliance**

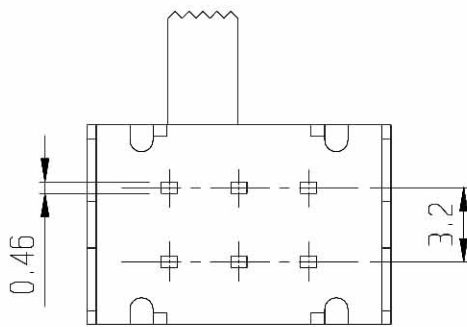

5	CONTACT	BRASS	2	Ag PLATED	6	SPRING	STEEL WIRE	2	
3	TERMINAL	BRASS	6	Ag PLATED	4	TERMINAL BASE	PHENOL RESIN	1	NATURAL
1	FRAME	S P C C	1	Ni PLATED	2	KNOB	P O M	1	EG 3-13
NO	PART	MATERIAL	QTY	REMARKS	NO	PART	MATERIAL	QTY	REMARKS

ISSUED

SPECIFICATION

TITLE: SIDE KNOB SLIDE SWITCH (2P2T)

RATING: DC 30V 0.3A
 CONTACT RESISTANCE: 30mΩ max.
 INSULATION RESISTANCE: 500MΩ at 500V DC
 WITHSTAND VOLTAGE: AC 500V for 1 minute
 OPERATION FORCE: REFER ATTACH SPECIFICATION
 SWITCHING LIFE: 10K cycles min.

MODEL NO: SK-22F18

TOLERANCE UNIT: MM
 UP TO 1.0:±0.1 SCALE: 3:1
 1.0 TO 10.0:±0.2 VERSION: 01
 OVER 10.0:±0.3 DRWG NO:

DWN. *hoo*
 CHK'D. *pu*
 APPD. *[Signature]*

BY: *[Signature]*

DATE: 01-SEP-2000

