

SCHMATIC

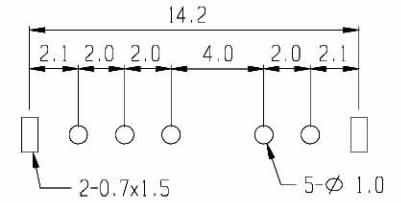

PCB LAYOUT

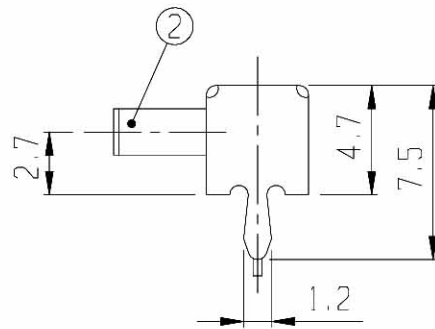
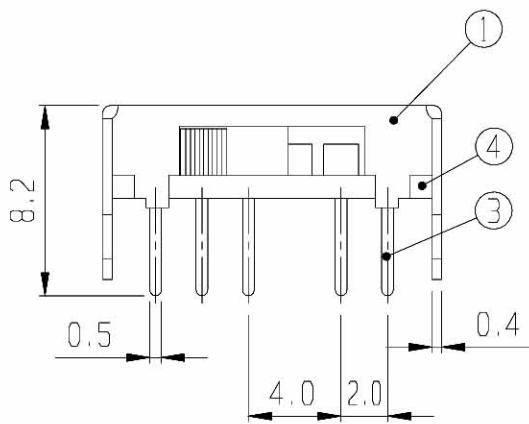

**RoHS
Compliance**

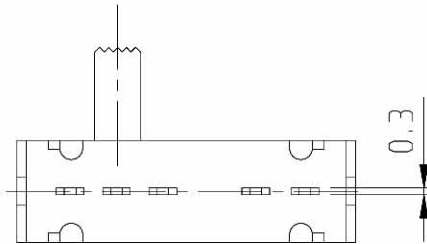

5	CONTACT	P B S	1	Ag PLATED	6	SPRING PLATE	P B S	1	
3	TERMINAL	BRASS	5	Ag PLATED	4	TERMINAL BASE	PHENOL RESIN	1	NATURAL
1	FRAME	S P C C	1	Ni PLATED	2	KNOB	P O M	1	EG 2-7
NO	PART	MATERIAL	QTY	REMARKS	NO	PART	MATERIAL	QTY	REMARKS

ISSUED	SPECIFICATION	TITLE: SIDE KNOB SLIDE SWITCH (1P4T)							
	RATING: DC 30V 0.5A	MODEL NO: SK-14D03							
	CONTACT RESISTANCE: 30mΩ max.	TOLERANCE		UNIT: MM		DWN.		<i>hno</i>	
	INSULATION RESISTANCE: 500MΩ at 500V DC	UP TO 1.0:±0.1		SCALE: 3:1		CHK'D.		<i>mu</i>	
	WITHSTAND VOLTAGE: AC 500V for 1 minute	1.0 TO 10.0:±0.2		VERSION: 02		APPD.		<i>[Signature]</i>	
	OPERATION FORCE: REFER ATTACH SPECIFICATION	OVER 10.0:±0.3		DRWG NO: 003					
	SWITCHING LIFE: 10K cycles min.								

BY: *[Signature]*
DATE: 24-AUG-2006

