

RoHS
Compliance

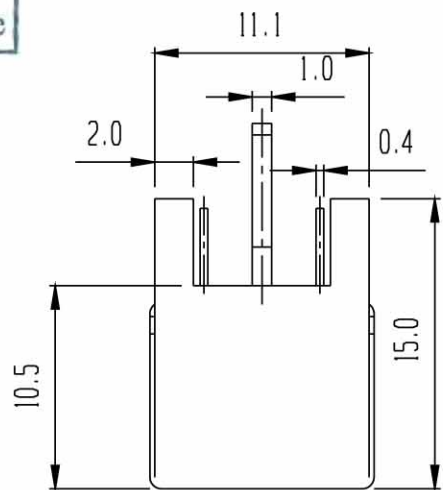
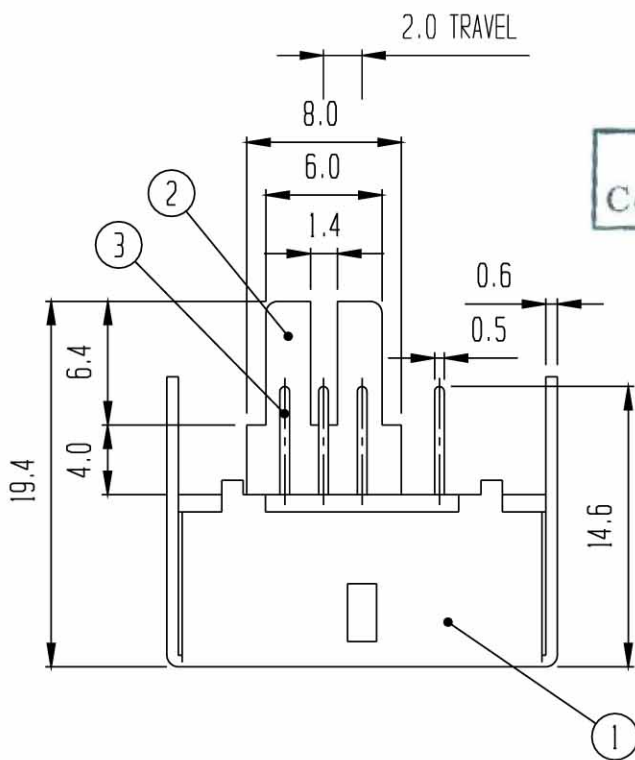

7	BALL	STEEL	2						
5	CONTACT	P B S	2	Ag PLATED	6	SPRING	STEEL WIRE	1	
3	TERMINAL	BRASS	8	Ag PLATED	4	TERMINAL BASE	PHENOL RESIN	1 NATURAL	
1	FRAME	SPCC	1	Ni PLATED	2	KNOB	POM+SPCC	1 BM 10.4	
NO.	PART	MATERIAL	QTY	REMARKS	NO.	PART	MATERIAL	QTY	REMARKS

ISSUED	SPECIFICATION	TITLE: BOTTOM KNOB SWITCH (2P3T)		
	RATING: DC 30V 0.5A	MODEL NO: BKS-23D01		
	CONTACT RESISTANCE: 30mΩ max.			
	INSULATION RESISTANCE: 500MΩ AT 500V DC	TOLERANCE	UNIT: MM	DWN. <i>hro</i>
	WITHSTAND VOLTAGE: AC 500V for 1 minute	UP TO 1.0:±0.1	SCALE: 2.5:1	
	OPERATION FORCE: REFER ATTACH SPECIFICATION	1.0 TO 10.0:±0.2	VERSION: 01	CHK'D. <i>mu</i>
	SWITCHING LIFE: 10K cycles min.	OVER 10.0:±0.3	DRWG NO:	APPD. <i>[Signature]</i>

BY: *[Signature]*
DATE: 20DEC-2000

